

P-6807-2

X647

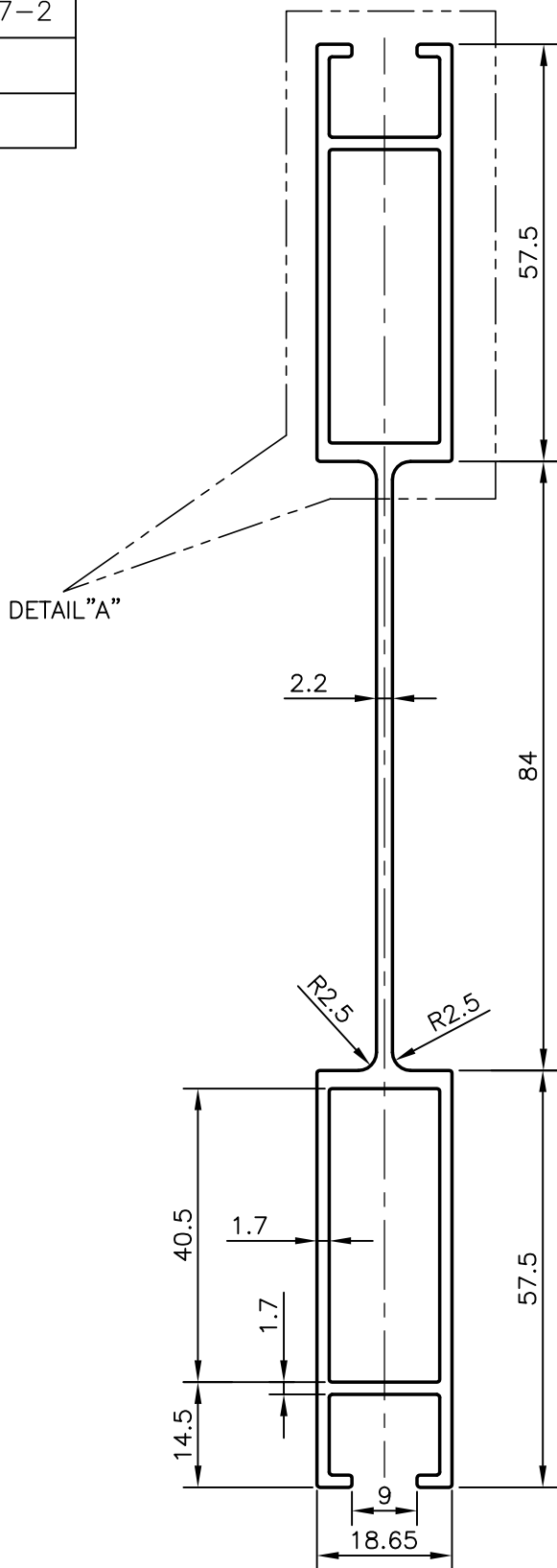

GENERAL WALL THICKNESS = 1.70mm



SYMBOL OF QUALITY
AN ISO 9002 COMPANY

JINDAL ALUMINIUM LTD.
BANGALORE-560073 (INDIA)

	NAME	DATE
DRAWN	RAGHAVENDRA	17-11-2006
CHECKED		
APPROVED		

1. ALL DIMENSIONS ARE IN mm.
2. ROUND OFF ALL SHARP CORNERS WITH 0.40 mm.
3. TOLERANCES WILL BE AS PER EN12020-2:2001 UNLESS OTHERWISE SPECIFIED

SCALE	1:1
AREA mm ²	730.515
PERIMETER mm.	535.988
WEIGHT kg/m	1.972

PARTY'S NAME	PROSOURCE SOLUTIONS INC., CANADA
PARTY'S DRAWING No.	AS PER SAMPLE & AS PER REQUIREMENT
ALLOY & TEMPER	6063 T5
DESCRIPTION	DISPLAY SECTION

DRAWING No.	SECTION No.
P-6807-2	-
X647	X647