

P-7517

X712

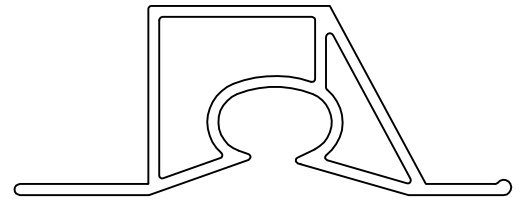

SCALE 1:1

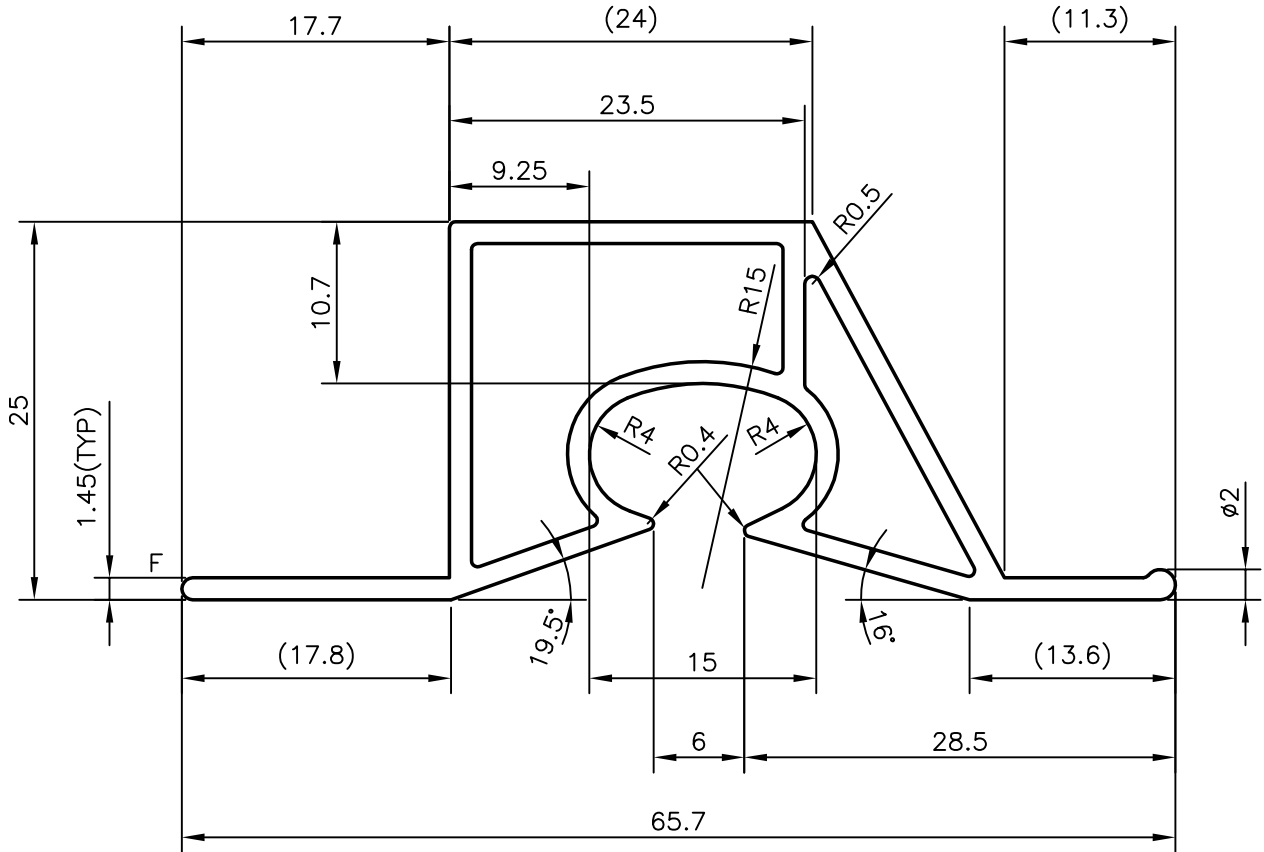

NOTE:-

1. F = FULL RADIUS (1 PLACE)
2. GENERAL WALL THICKNESS = 1.45 mm

 SYMBOL OF QUALITY AN ISO 9001 COMPANY	JINDAL ALUMINIUM LTD. BANGALORE-560073 (INDIA)	NAME		DATE
		DRAWN	PRASANN.H	25-09-2007
1. ALL DIMENSIONS ARE IN mm. 2. ROUND OFF ALL SHARP CORNERS WITH 0.40 mm. 3. TOLERANCES WILL BE AS PER IS:6477-1983 UNLESS OTHERWISE SPECIFIED		CHECKED		
		APPROVED		
PARTY'S NAME 3M INDIA LTD., BANGALORE		SCALE		2:1
		AREA mm ²		253.274
PARTY'S DRAWING No. AS PER SAMPLE		PERIMETER mm.		200.81
		WEIGHT kg/m		0.684
ALLOY & TEMPER HE9 WP		DRAWING No.		P-7517
		SECTION No.		-
DESCRIPTION MISC. SECTION		X712		X712