

P-7545

X718

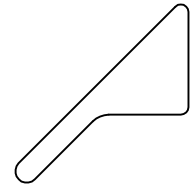

SCALE 1:1

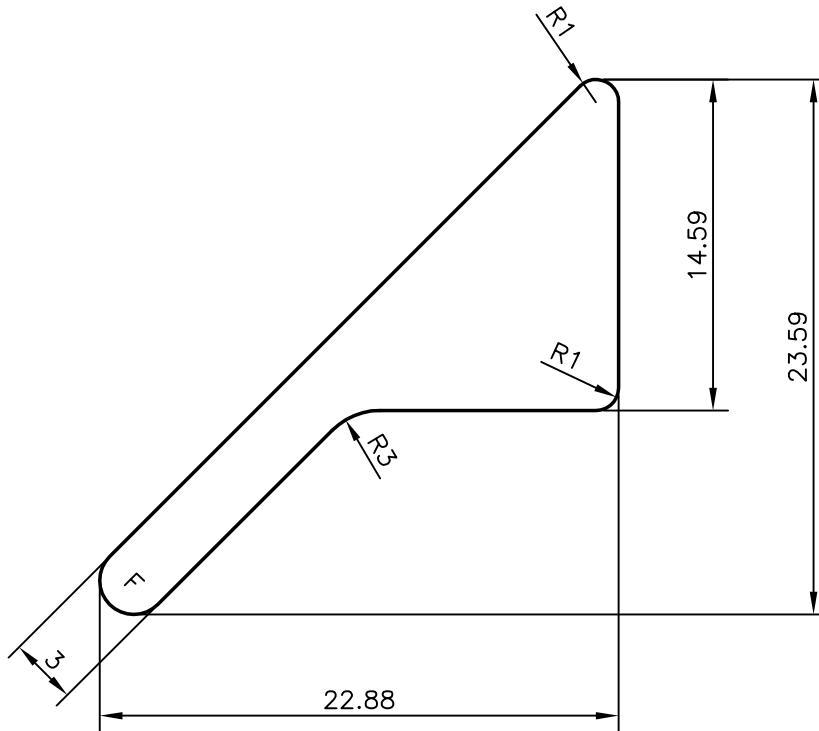

NOTE:-

1. SURFACE FINISH SHOULD BE GOOD
2. F = FULL RADIUS (1 PLACE)

 SYMBOL OF QUALITY AN ISO 9001 COMPANY	<b>JINDAL ALUMINIUM LTD.</b> BANGALORE-560073 (INDIA)	NAME		DATE
		DRAWN	PRASANN.H	08-10-2007
		CHECKED		
		APPROVED		
1. ALL DIMENSIONS ARE IN mm. 2. ROUND OFF ALL SHARP CORNERS WITH 0.40 mm. 3. TOLERANCES WILL BE AS PER IS:3965-1981 UNLESS OTHERWISE SPECIFIED		SCALE		3:1
		AREA mm <sup>2</sup>		162.148
		PERIMETER mm.		73.29
		WEIGHT kg/m		0.438
PARTY'S NAME	SRINU ENGINEERING INDUSTRIES, BANGALORE	DRAWING No.		SECTION No.
PARTY'S DRAWING No.	3.400.1490	P-7545		-
ALLOY & TEMPER	HE9 WP	X718		X718
DESCRIPTION	MISC. SECTION			