

10.25±0.25

DETAIL OF "A"  
SCALE 3:1

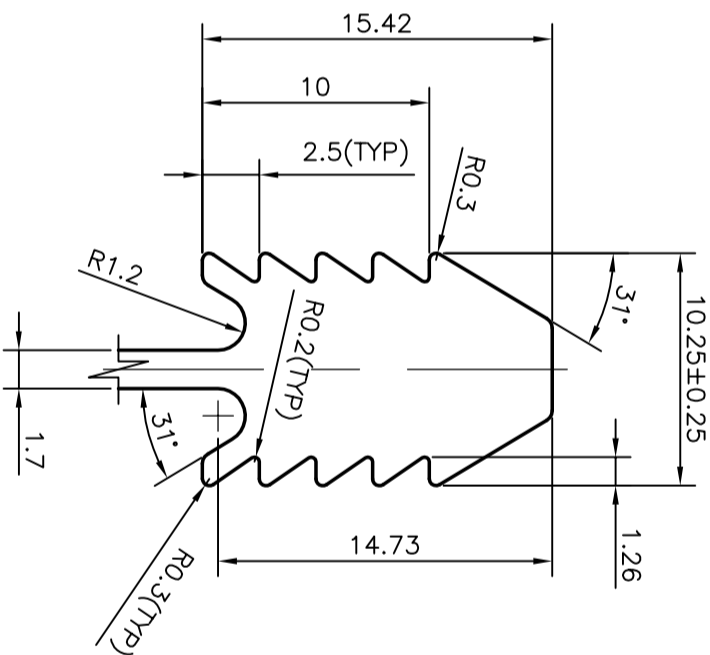

SCALE 1:1

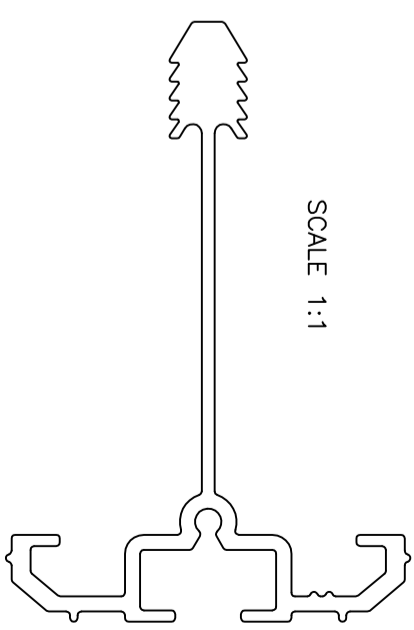

DETAIL OF "B"  
SCALE 3:1

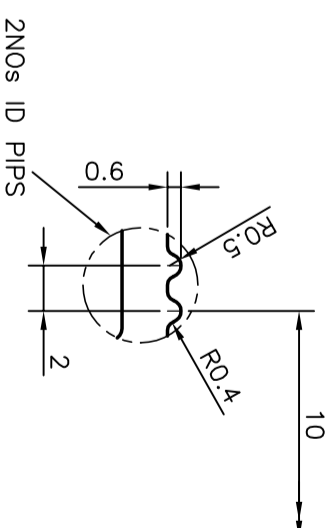

UNSPECIFIED RADIUS IS R0.50 mm

 <p>SYMBOL OF QUALITY AN ISO 9001 COMPANY</p>		<p><b>JINDAL ALUMINIUM LTD.</b> BANGALORE-560073 (INDIA)</p>		<p>NAME PRASANN. H</p>	<p>DATE 19-11-2007</p>
<p>1. ALL DIMENSIONS ARE IN mm. 2. ROUND OFF ALL SHARP CORNERS WITH 0.50 mm. 3. TOLERANCES WILL BE AS PER BS:EN-755 UNLESS OTHERWISE SPECIFIED</p>		<p>SCALE 2:1</p>		<p>CHECKED</p>	
<p>PARTY'S NAME SYNSEAL EXTRUSIONS LTD., U.K</p>		<p>AREA mm<sup>2</sup> 424.48</p>		<p>APPROVED</p>	
<p>PARTY'S DRAWING No. XT2/2 ISSUE NO. ORDER A</p>		<p>PERIMETER mm. 372.958</p>		<p>WEIGHT kg/m 1.146</p>	
<p>ALLOY &amp; TEMPER 6063 T6</p>		<p>DRAWING No. P-7612-1</p>		<p>SECTION No. -</p>	
<p>DESCRIPTION MEDIUM TRANSOM XT2</p>		<p>DRAWING No. X724</p>		<p>SECTION No. X724</p>	