

DETAIL OF "A"
SCALE 3:1

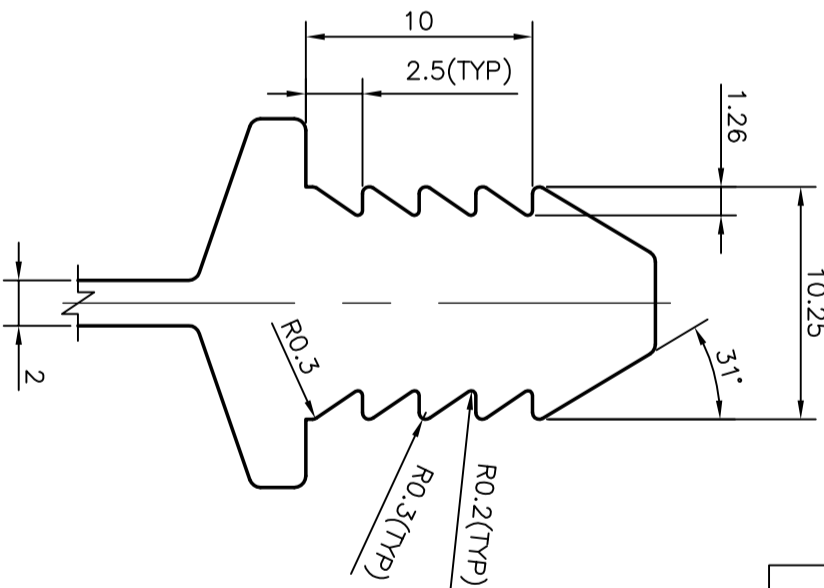

DETAIL OF "B"
SCALE 3:1

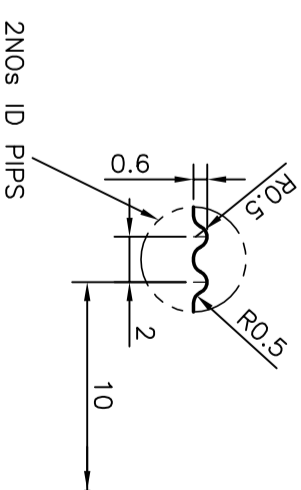

F = FULL RADIUS (4 PLACES)
UNSPECIFIED RADIUS = R0.50 mm

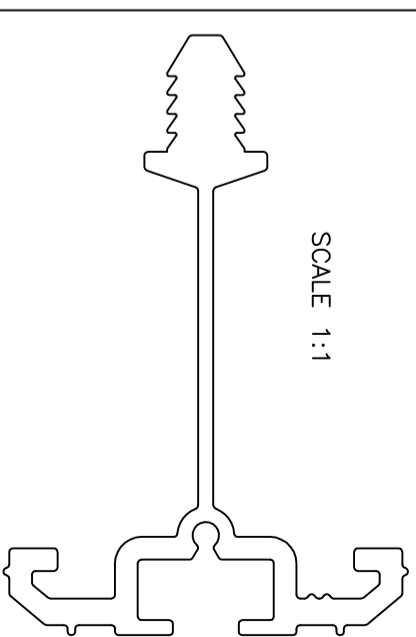

SCALE 1:1

 <p>SYMBOL OF QUALITY AN ISO 9001 COMPANY</p>	<p>JINDAL ALUMINIUM LTD. BANGALORE-560073 (INDIA)</p>		NAME	DATE
	<p>1. ALL DIMENSIONS ARE IN mm. 2. ROUND OFF ALL SHARP CORNERS WITH 0.50 mm. 3. TOLERANCES WILL BE AS PER BS:EN-755 UNLESS OTHERWISE SPECIFIED</p>	<p>PARTY'S NAME SYNSEAL EXTRUSIONS LTD., U.K</p>	<p>DRAWN PRASANN. H</p>	<p>19-11-2007</p>
<p>PARTY'S DRAWING No. XT3/2 ISSUE NO. ORDER A</p>	<p>ALLOY & TEMPER 6063 A T6</p>	<p>CHECKED</p>	<p>APPROVED</p>	<p>SCALE 2:1</p>
<p>DESCRIPTION HEAVY TRANSOM XT3</p>	<p>AREA mm² 579.369</p>	<p>PERIMETER mm. 368.007</p>	<p>WEIGHT kg/m 1.564</p>	<p>DRAWING No. P-7615-1</p>
				<p>SECTION No. X727</p>