

P-7848

X765

DETAIL OF "A"
SCALE 3:1

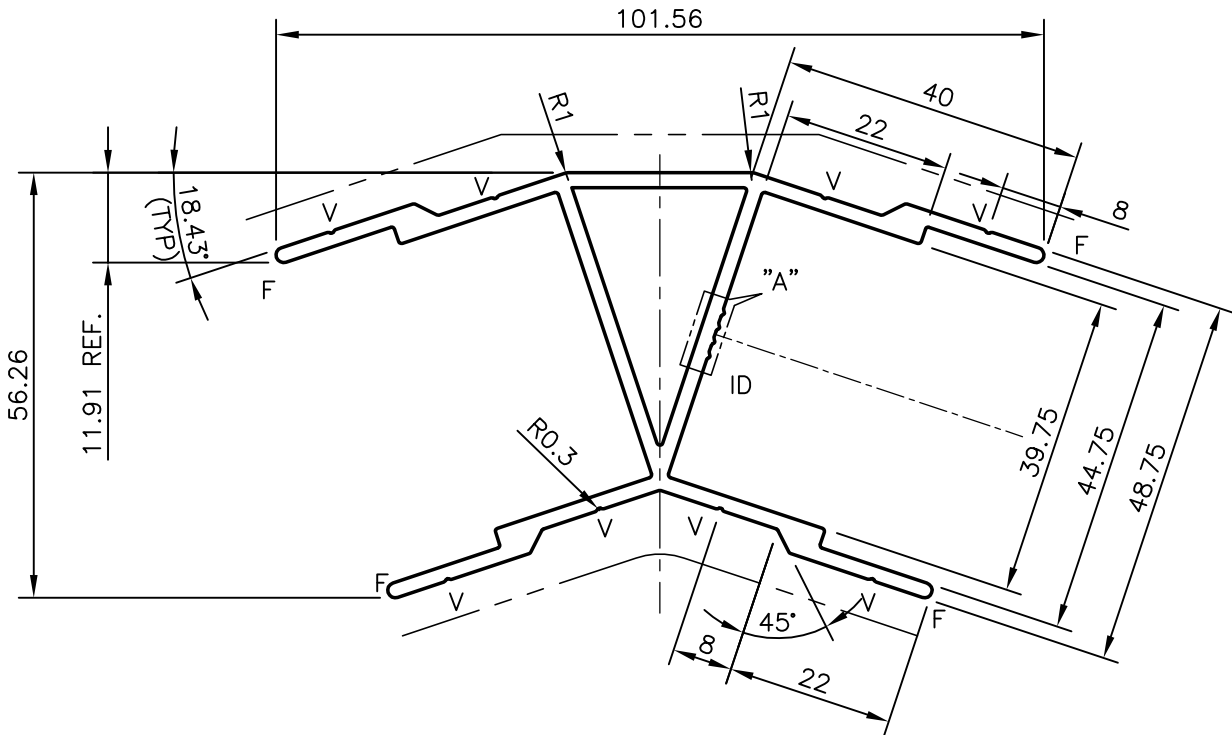
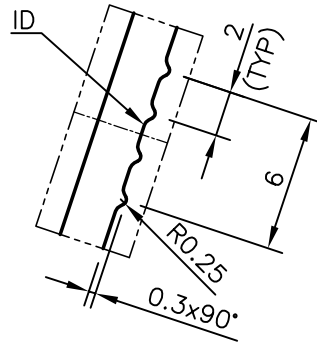

----- EXPOSED SURFACE
 V = 'V'-GROOVE 0.3x90° (8 PLACES)
 UNSPECIFIED WALL THICKNESS = 2±0.18 mm
 F = FULL RADIUS (4 PLACES)



SYMBOL OF QUALITY
AN ISO 9001 COMPANY

JINDAL ALUMINIUM LTD.
BANGALORE-560073 (INDIA)

	NAME	DATE
DRAWN	PRASANNA. H	14-01-2008
CHECKED		
APPROVED		

1. ALL DIMENSIONS ARE IN mm.
2. ROUND OFF ALL SHARP CORNERS WITH 0.40 mm.
3. TOLERANCES WILL BE AS PER BS:EN-755 UNLESS OTHERWISE SPECIFIED

SCALE	1:1
AREA mm ²	564.691
PERIMETER mm.	431.669
WEIGHT kg/m	1.525

PARTY'S NAME	PROSOURCE SOLUTIONS INC., CANADA
PARTY'S DRAWING No.	7811 H
ALLOY & TEMPER	6063 T5
DESCRIPTION	ROOF CHANNEL SECTION

DRAWING No.	SECTION No.
P-7848	-
X765	X765