

P-7982

X790

SCALE 1:1

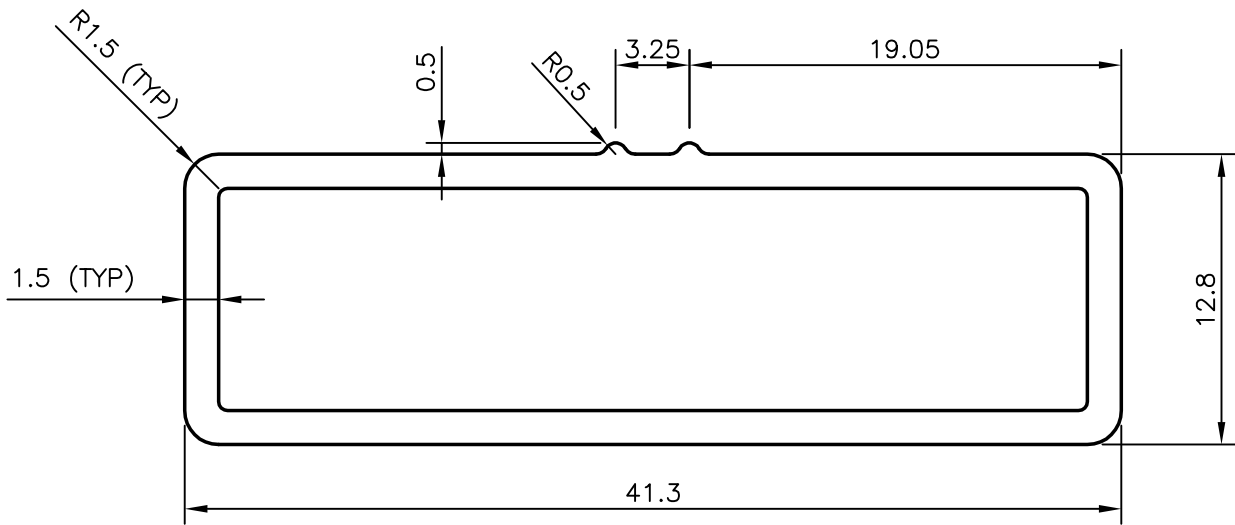

SYMBOL OF QUALITY
AN ISO 9001 COMPANY

JINDAL ALUMINIUM LTD.
BANGALORE-560073 (INDIA)

	NAME	DATE
DRAWN	PRASANNA.H	11-03-2008
CHECKED		
APPROVED		

1. ALL DIMENSIONS ARE IN mm.
2. ROUND OFF ALL SHARP CORNERS WITH 0.40 mm.
3. TOLERANCES WILL BE AS PER BS:EN-755 UNLESS OTHERWISE SPECIFIED

SCALE	3:1
AREA mm ²	152.372
PERIMETER mm.	106.349
WEIGHT kg/m	0.411

PARTY'S NAME SYNSEAL EXTRUSIONS LTD., U.K.

PARTY'S DRAWING No. 5RA-FT1 (98-11574)

ALLOY & TEMPER 6063 T6

DESCRIPTION RECTANGULAR TUBE MISC.

DRAWING No.	SECTION No.
P-7982	-
X790	X790