

P-8209-1

X905

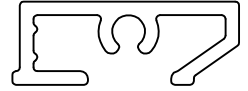

SCALE 1:1

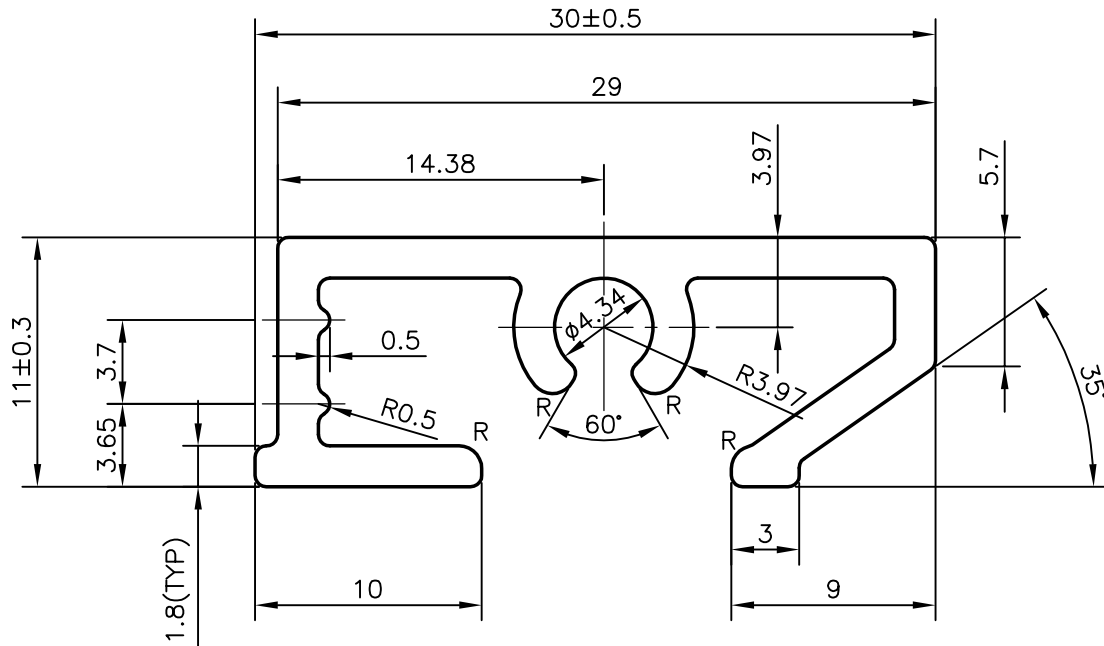

R = R1.0 mm (2 PLACES)  
 UNSPECIFIED WALL THICKNESS = 1.80 mm  
 UNSPECIFIED RADIUS = R0.50 mm



SYMBOL OF QUALITY  
 AN ISO 9001 COMPANY

**JINDAL ALUMINIUM LTD.**  
 BANGALORE-560073 (INDIA)

	NAME	DATE
DRAWN	PRASANNA.H	12-05-2008
CHECKED		
APPROVED		

1. ALL DIMENSIONS ARE IN mm.
2. ROUND OFF ALL SHARP CORNERS WITH 0.50 mm.
3. TOLERANCES WILL BE AS PER BS:EN-755 UNLESS OTHERWISE SPECIFIED

SCALE	3:1
AREA mm <sup>2</sup>	128.202
PERIMETER mm.	139.062
WEIGHT kg/m	0.346

PARTY'S NAME	SYNSEAL EXTRUSIONS LTD., U.K.
PARTY'S DRAWING No.	PR10
ALLOY & TEMPER	6063 T6
DESCRIPTION	PR10 PATIO MID RAIL MECH JOINT

DRAWING No.	SECTION No.
P-8209-1	-
X905	X905