

P-8220-1

X915

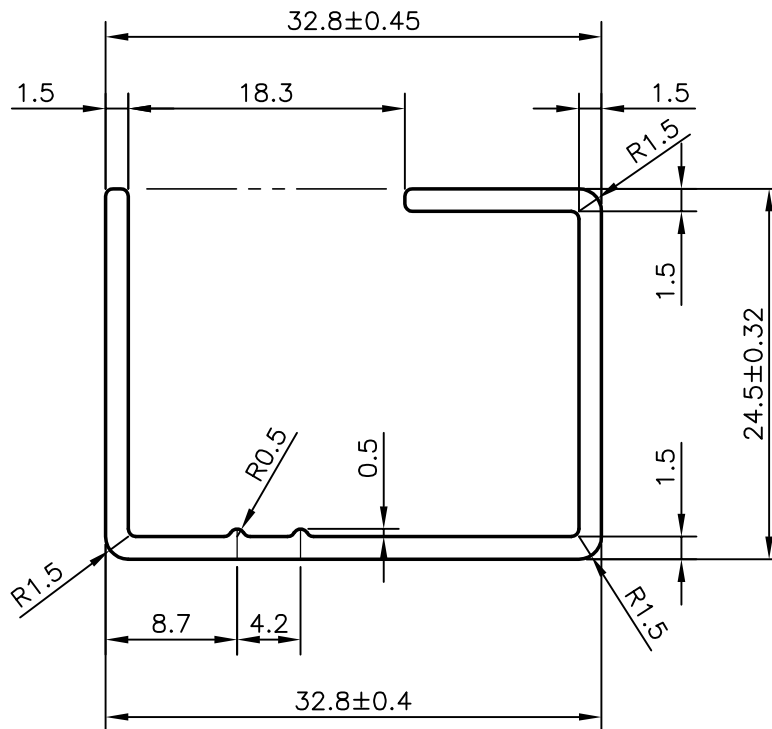

UNSPECIFIED RADIUS = R0.50 mm

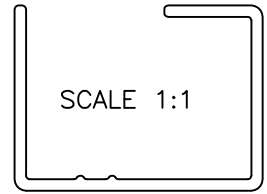

SYMBOL OF QUALITY
AN ISO 9001 COMPANY

JINDAL ALUMINIUM LTD.
BANGALORE-560073 (INDIA)

	NAME	DATE
DRAWN	PRASANNA.H	12-05-2008
CHECKED		
APPROVED		

1. ALL DIMENSIONS ARE IN mm.
2. ROUND OFF ALL SHARP CORNERS WITH 0.50 mm.
3. TOLERANCES WILL BE AS PER BS:EN-755 UNLESS OTHERWISE SPECIFIED

SCALE	2:1
AREA mm ²	134.814
PERIMETER mm.	180.891
WEIGHT kg/m	0.364

PARTY'S NAME	SYNSEAL EXTRUSIONS LTD., U.K.
PARTY'S DRAWING No.	5RA-V2 (98-11575) / ISSUE NO. ORDER A
ALLOY & TEMPER	6063 T6
DESCRIPTION	LEGEND 70 GLAZE-IN VENT (ALI)

DRAWING No.	SECTION No.
P-8220-1	-
X915	X915