

P-8222-1

X916

SCALE 1:1

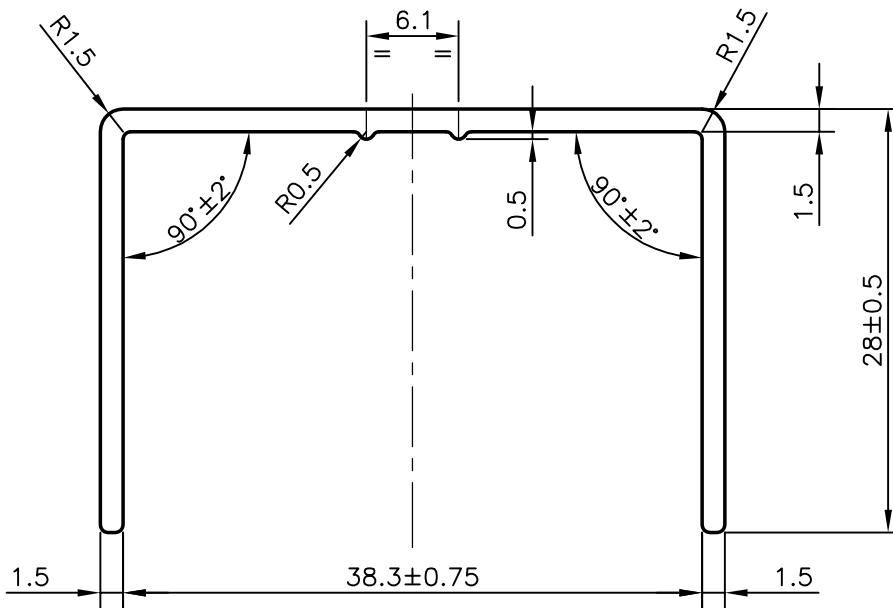

UNSPECIFIED RADIUS = R0.50 mm



SYMBOL OF QUALITY
AN ISO 9001 COMPANY

JINDAL ALUMINIUM LTD.
BANGALORE-560073 (INDIA)

	NAME	DATE
DRAWN	PRASANNA.H	12-05-2008
CHECKED		
APPROVED		

1. ALL DIMENSIONS ARE IN mm.
2. ROUND OFF ALL SHARP CORNERS WITH 0.50 mm.
3. TOLERANCES WILL BE AS PER BS:EN-755 UNLESS OTHERWISE SPECIFIED

SCALE	2:1
AREA mm ²	141.243
PERIMETER mm.	189.749
WEIGHT kg/m	0.381

PARTY'S NAME	SYNSEAL EXTRUSIONS LTD., U.K.
PARTY'S DRAWING No.	5RA-TT1 (98-11577) / ISSUE NO. ORDER A
ALLOY & TEMPER	6063 T6
DESCRIPTION	LEGEND 70 TILT & TURN (ALI)

DRAWING No.	SECTION No.
P-8222-1	-
X916	X916