

P-8229-1

X932

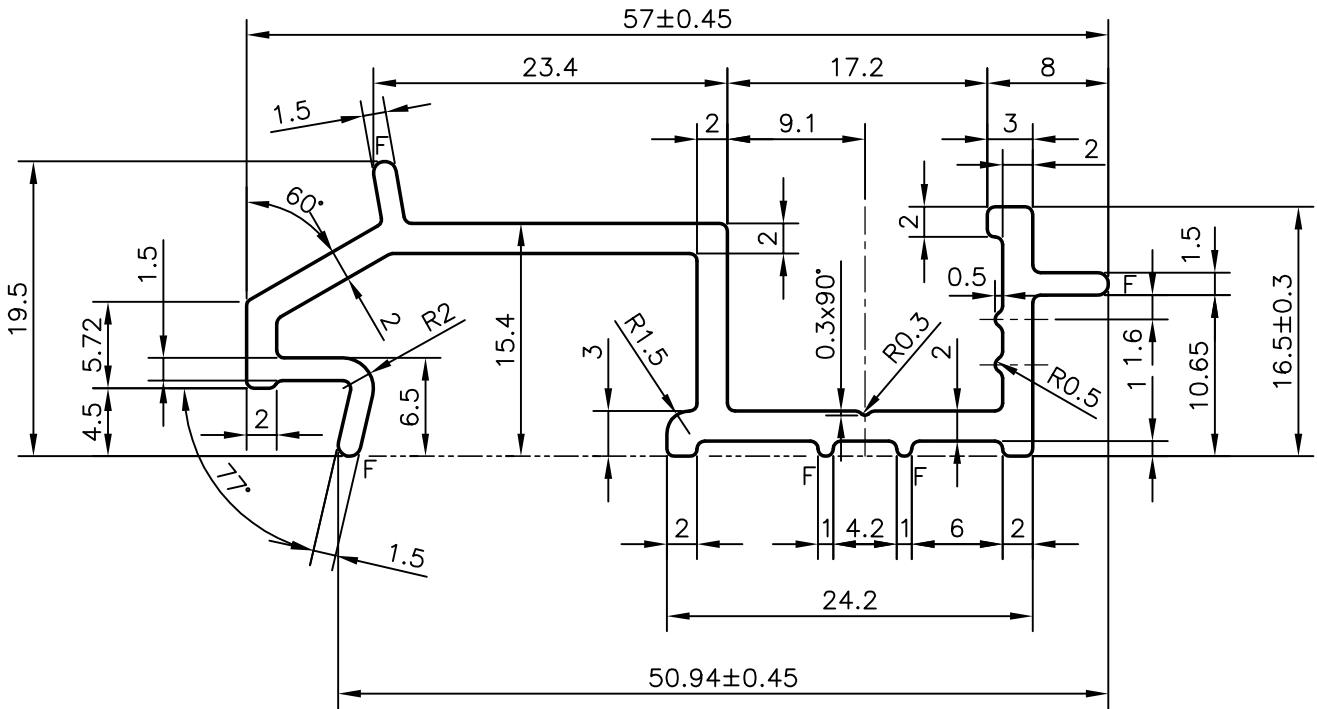

F = FULL RADIUS (5 PLACES)
 UNSPECIFIED RADIUS = R0.50 mm

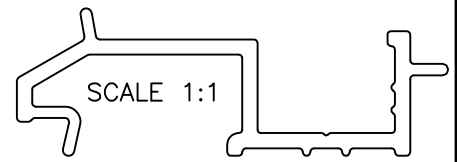

SYMBOL OF QUALITY
 AN ISO 9001 COMPANY

JINDAL ALUMINIUM LTD.
 BANGALORE-560073 (INDIA)

	NAME	DATE
DRAWN	PRASANNA.H	08-05-2008
CHECKED		
APPROVED		

1. ALL DIMENSIONS ARE IN mm.
2. ROUND OFF ALL SHARP CORNERS WITH 0.50 mm.
3. TOLERANCES WILL BE AS PER BS:EN-755 UNLESS OTHERWISE SPECIFIED

SCALE	2:1
AREA mm ²	208.354
PERIMETER mm.	216.684
WEIGHT kg/m	0.562

PARTY'S NAME	SYNSEAL EXTRUSIONS LTD., U.K.
PARTY'S DRAWING No.	5RA-DMP / ISSUE NO. ORDER A
ALLOY & TEMPER	6063 T6
DESCRIPTION	LEGEND 70 DUMMY MULLION PACKER (ALI)

DRAWING No.	SECTION No.
P-8229-1	-
X932	X932