

DETAIL "B"
SCALE 3:1

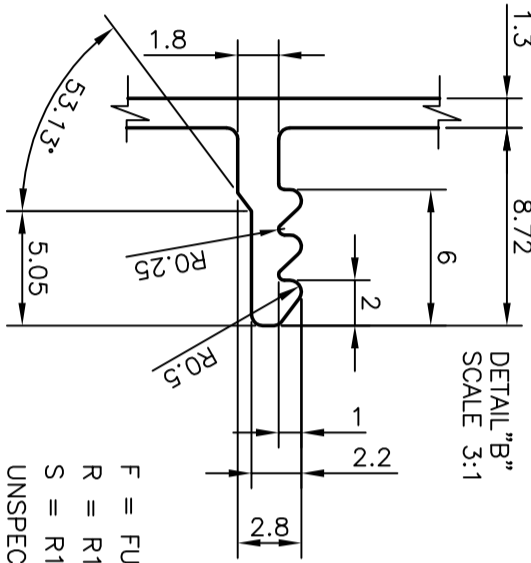

F = FULL RADIUS (2 PLACES)
R = R1.50 mm (8 PLACES)
S = R1.00 mm (7 PLACES)
UNSPECIFIED RADIUS = R0.50 mm

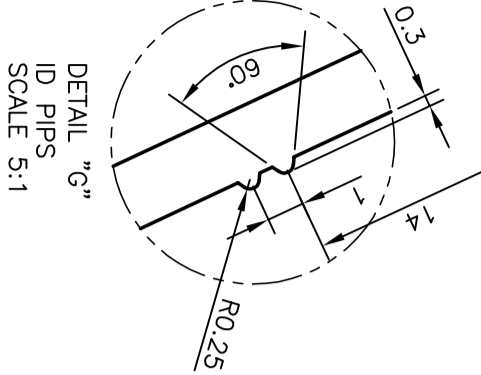
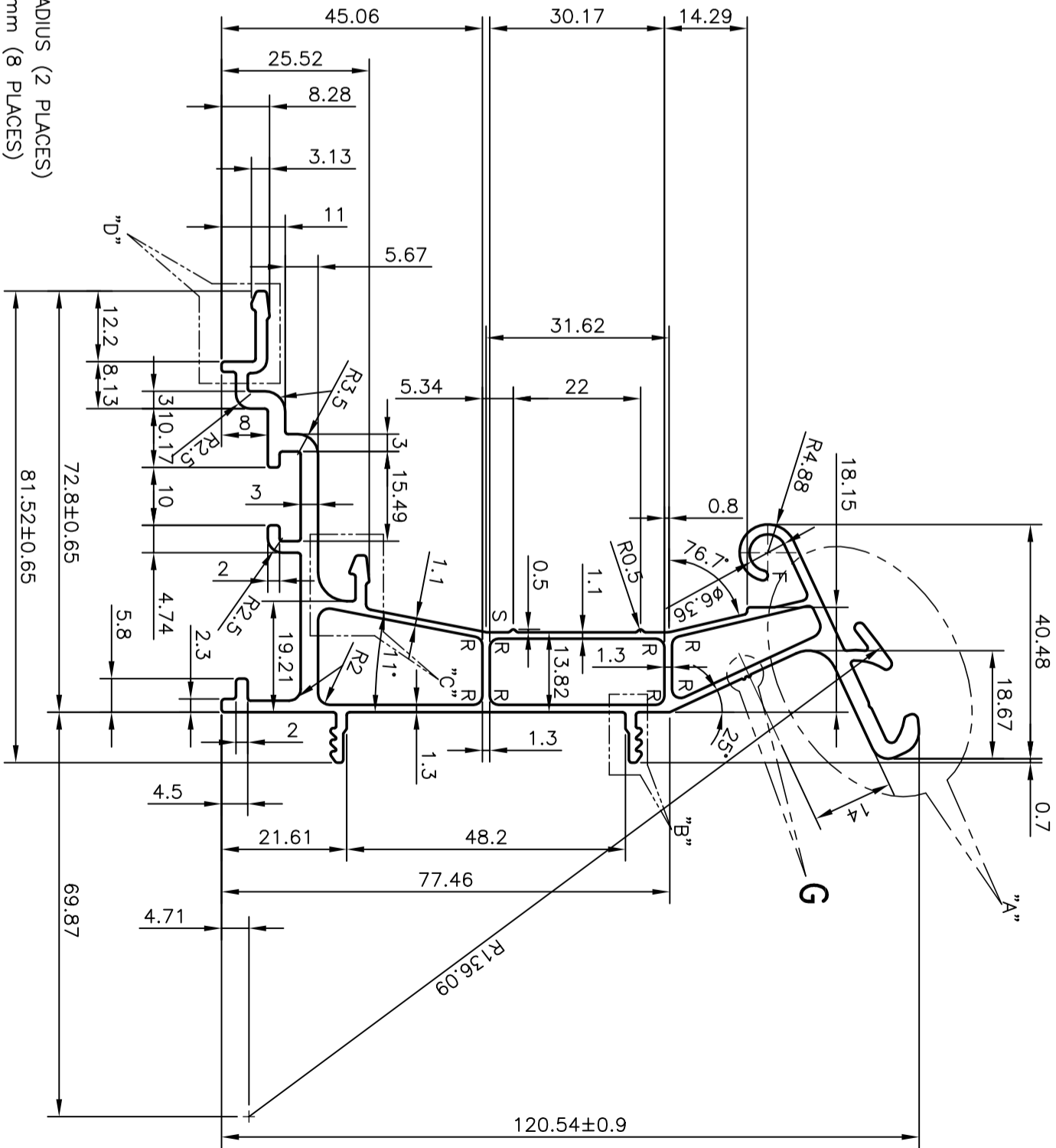

DETAIL "D"
SCALE 3:1

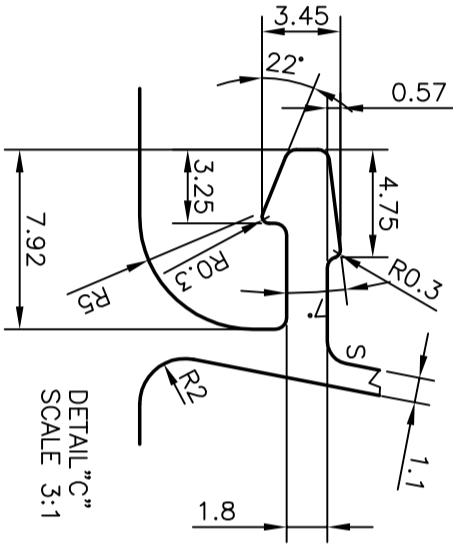

DETAIL "C"
SCALE 3:1

ISSUE-2 ID PIPS ADDED AS PER PARTY'S REQUIREMENT

JINDAL
SYMBOL OF QUALITY
AN ISO 9001 COMPANY
JINDAL ALUMINIUM LTD.
BANGALORE-560073 (INDIA)

1. ALL DIMENSIONS ARE IN mm.
2. ROUND OFF ALL SHARP CORNERS WITH 0.40 mm.
3. TOLERANCES WILL BE AS PER BS:EN-755 UNLESS OTHERWISE SPECIFIED

PARTY'S NAME
SYNSEAL EXTRUSIONS LTD., U.K

PARTY'S DRAWING No.
XEB6

ALLOY & TEMPER
6063 T6

DESCRIPTION
EAVES BEAM XEB6

NAME	DATE
RAGHAVENDRA	18-12-2008
CHECKED	
APPROVED	
SCALE	1:1
AREA mm ²	789.154
PERIMETER mm.	593.214
WEIGHT kg/m	2.131
DRAWING No.	SECTION No.
P-8449	-
X972	X972-ISSUE-2