

P-JAL-B-259

XX0004

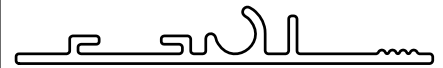

SCALE-1:1

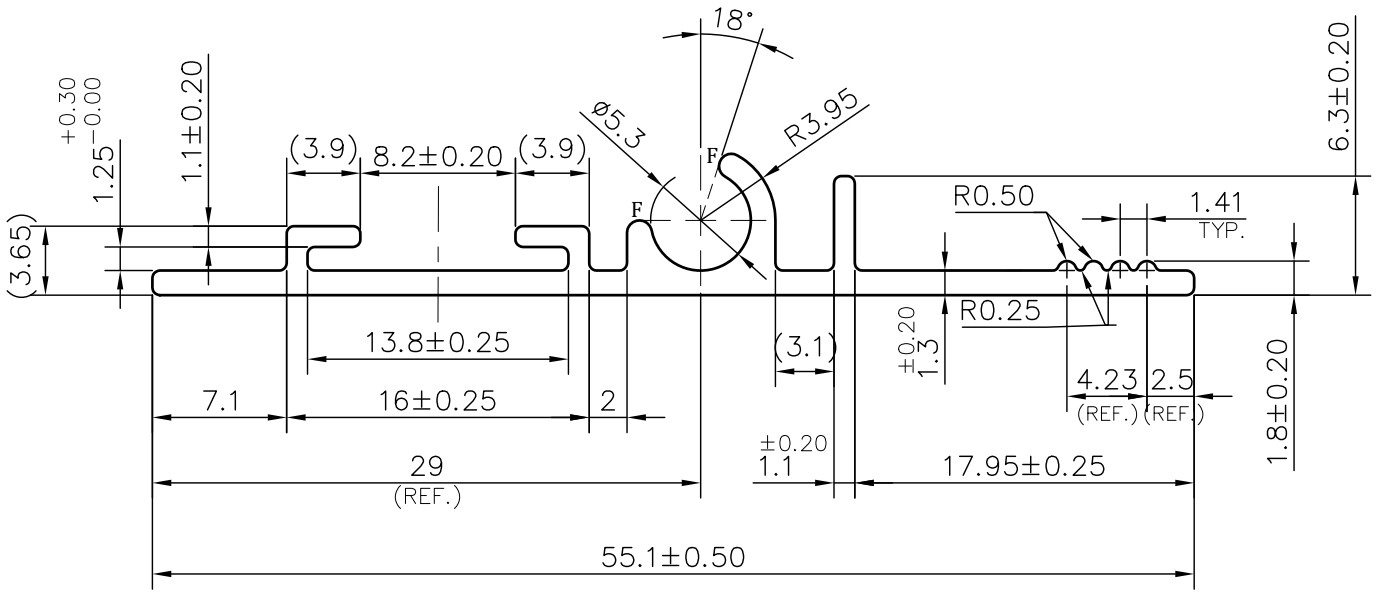

ISSUE-②: 23.09.2023
2 NOS. OF SERRATION REMOVED

NOTE:-

F= FULL RADIUS (2 PLACES)

1. STRAIGHTNESS= 1.7mm/M
2. TWIST= 1.7mm/M
3. ANGULARITY= ±2°
4. FLATNESS= 0.007xWIDTH

Q00733



SYMBOL OF QUALITY
AN ISO 9001 COMPANY

JINDAL ALUMINIUM LTD.
BHIWADI-301019 (INDIA)

	NAME	DATE
DRAWN	ASHUTOSH	23-09-2023
CHECKED	PARVESH	26-09-2023
APPROVED	J.N RAI	26-09-2023

1. ALL DIMENSIONS ARE IN mm.
2. ROUND OFF ALL SHARP CORNERS WITH 0.40 mm.
3. TOLERANCES WILL BE AS PER BS:EN-755-9 , UNLESS OTHERWISE SPECIFIED

SCALE	2.5:1
AREA mm ²	104.849
PERIMETER mm.	156.86
WEIGHT kg/m	0.283

PARTY'S NAME	ADMORE AIRTECH PVT. LTD., NOIDA	DRAWING No.	P-JAL-B-259	SECTION No.	
PARTY'S DRAWING No.	AS PER DRAWING		XX0004-ISSUE-2		XX0004
ALLOY & TEMPER	6063 T6	PRODUCT CODE: -082			
		HSN CODE: - 76042990			
DESCRIPTION	AIR GRILL SECTION				