

ASSEMBLY

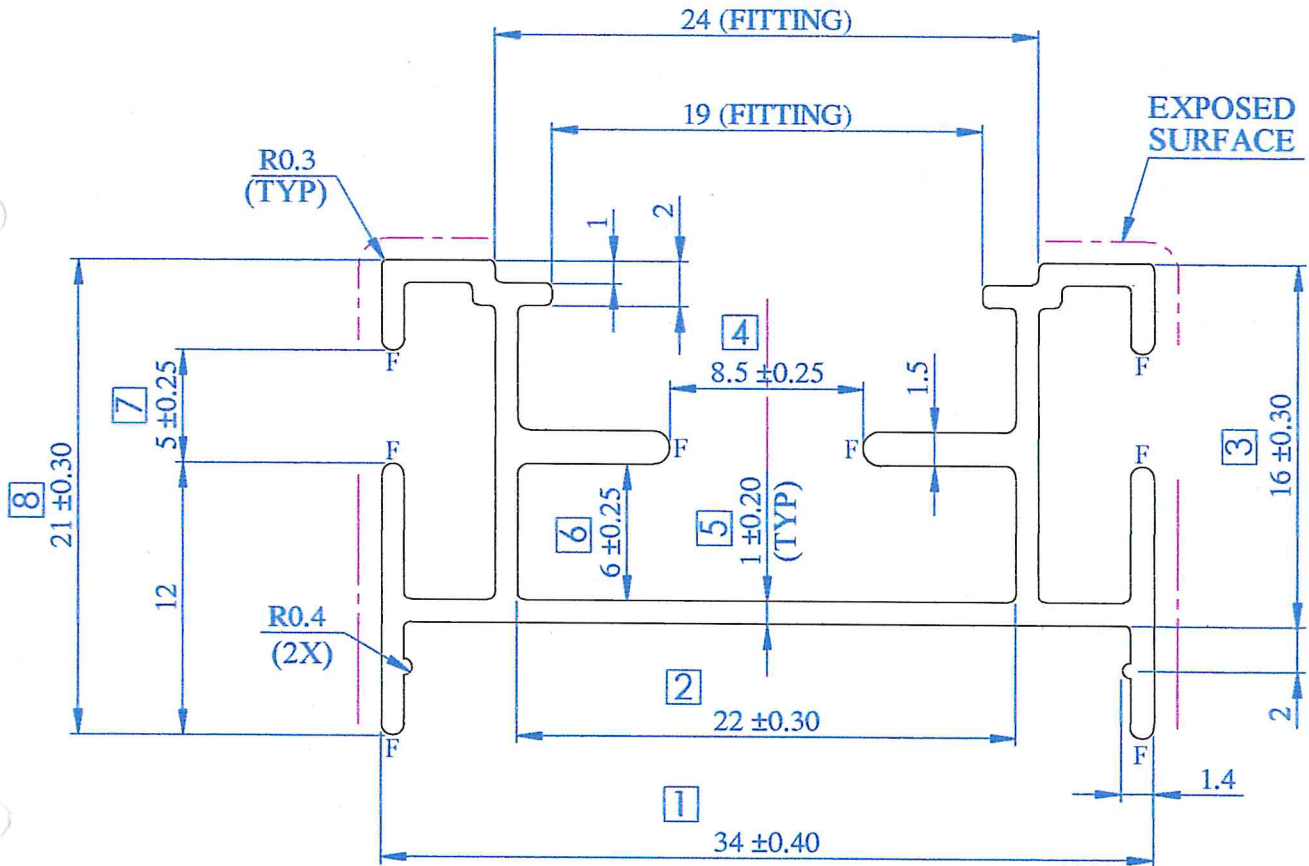
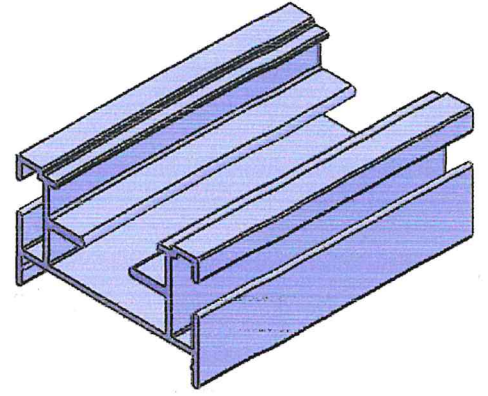

TOP BAR

NOTE:-

F= Full Radius

LOCATION:-P3 - 2HOLE  
ALL DIMENSION ARE IN mm.  
UNSPECIFIED CORNER RADIUS:0.40

**PLEASE SPECIFY THE EXPOSED SURFACE**

TOL. AS PER BS EN 755-9: 2008  
UNLESS SPECIFIED

TWIST=±1/4°/300 M.M./M.  
FLATNESS= WIDTH X 0.005mm.  
STRAIGHTNESS= 1.50 M.M./MTR.  
ANGULARITY=±1.5°

**INDO ALUSYS INDUSTRIES LIMITED BHIWADI RAJASTHAN - 301019**

PARTY SAMPLE & DRG. 34TB34		PARTY NAME M/S HARMONY SYSTEM			REF:- AS PER EMAIL ON Dt.-24.09.15		
			DRAWN	DHARMVIR	25.09.15	AREA	124.90 MM <sup>2</sup>
			CHECKED	<i>[Signature]</i>		WEIGHT	0.337 KG/M.
			APPROVED	<i>[Signature]</i>	18/11/15	WT. RANGE	----- Kg/12'
			SCALE	1:1 & 3:1	DATE	ALLOY	6063-T6
00	(REF.)		CRITICAL DIM. *			MAL NO	15154
REV. STATUS	REV. NO.	DESCRIPTION	SIGN DATE	PERIMETER	INT.	SEC.NO.	D-6525
A4		REVISION			EXT.		