

P-JAL-B-555-1

X102369

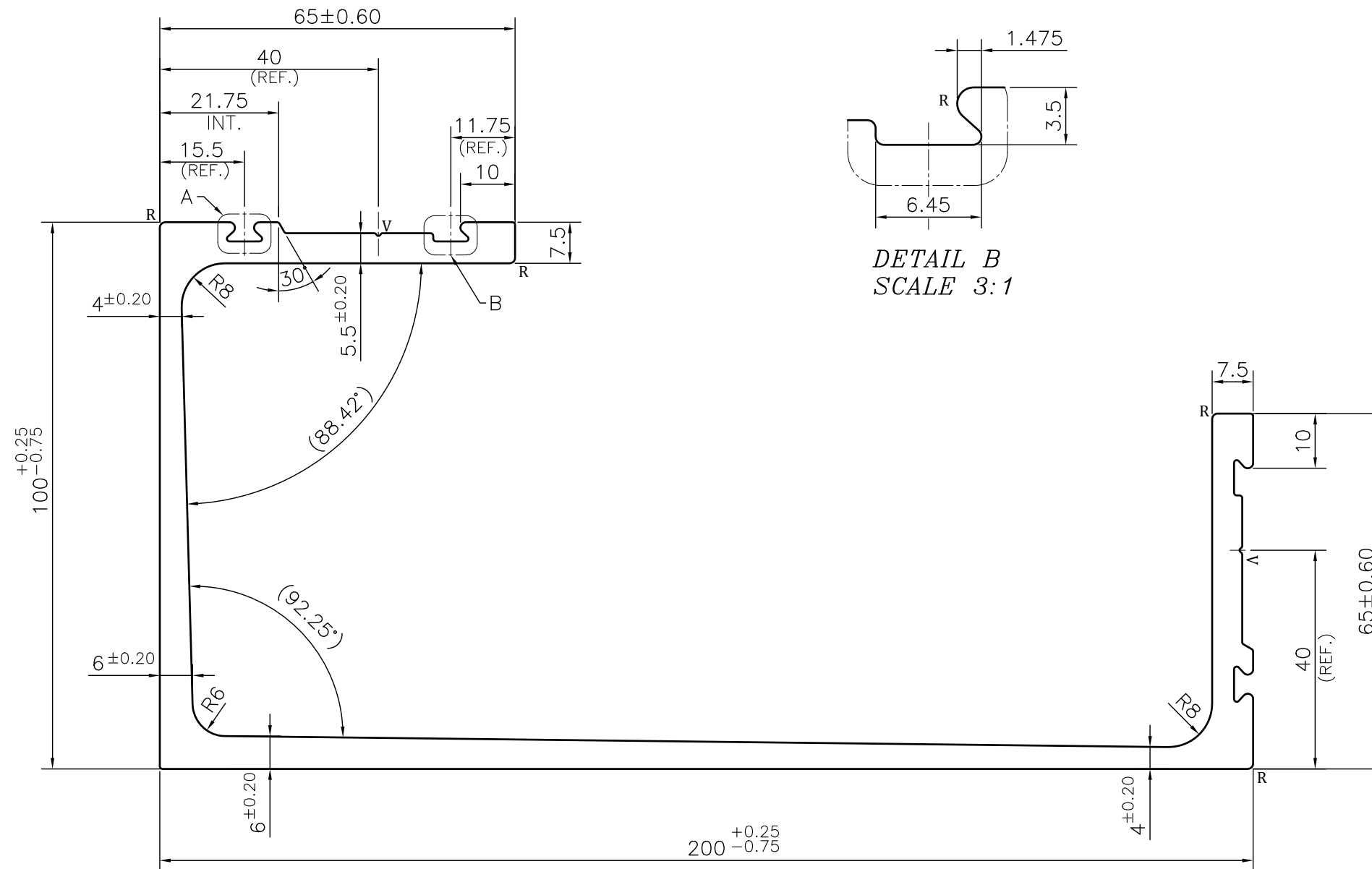
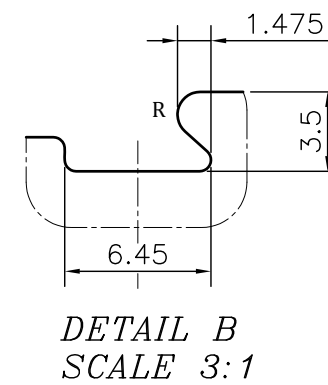
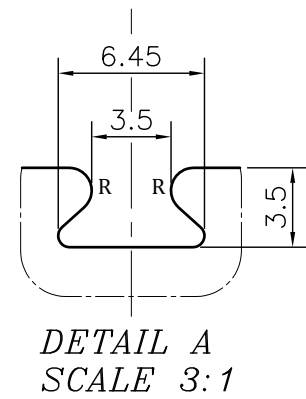

NOTE:-

- ☞ ROUND OFF ALL SHARP CORNERS WITH 0.50 mm.
- ☞ FE:- NOT MORE THAN 0.4%, MG:- 0.8 TO 1.2%
- ☞ HARDNESS :- 56HRB
- ☞ UTS :- 280 TO 300 MIN MPA

NOTE:-

- R= 1.0 RADIUS (10 PLACES)**
- V= 0.5x60° V-GROOVE (2 PLACES)**

1. STRAIGHTNESS= 1.0mm/M
2. TWIST= 1.0mm/M
3. ANGULARITY= ±1°
4. FLATNESS= ±0.5mm

Q01936

CONTROLLED COPY

<p>SYMBOL OF QUALITY AN ISO 9001 COMPANY</p>	<p>JINDAL ALUMINIUM LTD. BHIWADI-301019 (INDIA)</p>	NAME	DATE
		DRAWN	ASHUTOSH 01-06-2024
<p>1. ALL DIMENSIONS ARE IN mm. 2. ROUND OFF ALL SHARP CORNERS WITH 0.50 mm. 3. TOLERANCES WILL BE AS PER EN 12020-2, UNLESS OTHERWISE SPECIFIED</p>		CHECKED	PARVESH 15-06-2024
		APPROVED	N.K.HOLEY 15-06-2024
<p>PARTY'S NAME KNEST MANUFACTURERS LLP, PUNE</p>		SCALE	1:1
		AREA mm ²	2221.639
<p>PARTY'S DRAWING No. AS PER DRAWING</p>		PERIMETER mm.	862.68
		WEIGHT kg/m	5.998
<p>ALLOY & TEMPER 6061 T6</p>		DRAWING No.	SECTION No.
		P-JAL-B-555-1	7000002547
<p>DESCRIPTION FORM WORK SECTION- 200 IC</p>		X102369	X102369
		PRODUCT CODE:-029	
		HSN CODE:- 76042990	